

***DRV-1  
USERS GUIDE***

*Revision Date: 11/25/2009*

## Table of Contents

<b><i>Introduction.....</i></b>	<b><i>3</i></b>
<b><i>Product Overview .....</i></b>	<b><i>4</i></b>
<b><i>Design Tips .....</i></b>	<b><i>4</i></b>
<b><i>Installation.....</i></b>	<b><i>6</i></b>
<b><i>DRV-1 Assembly Drawing.....</i></b>	<b><i>7</i></b>
<b><i>Control / Motor/ Power Input (J2).....</i></b>	<b><i>7</i></b>
<b><i>Microstep Resolution (JP1) .....</i></b>	<b><i>8</i></b>
<b><i>Stepping Motors .....</i></b>	<b><i>8</i></b>
<b><i>Setting the Output Current (Pot 1) .....</i></b>	<b><i>9</i></b>
<b><i>Connecting Power Supplies (J2).....</i></b>	<b><i>9</i></b>
<b><i>Fault Protection .....</i></b>	<b><i>10</i></b>
<b><i>Electrical Specifications .....</i></b>	<b><i>10</i></b>
<b><i>Thermal/Mechanical Specifications.....</i></b>	<b><i>10</i></b>
<b><i>Mounting Dimensions .....</i></b>	<b><i>11</i></b>

## Introduction

Congratulations on your purchase of an AMS model DRV-1 Microstepping Driver. The DRV-1 will provide years of reliable, accurate and cost-effective motion control. As with all AMS products the DRV-1 is backed by over three decades of manufacturing excellence and a commitment to quality and support that guarantees your satisfaction.

This Technical Reference Guide will assist you in optimizing the performance of your DRV-1 driver. Its purpose is to provide access to information that will facilitate a reliable and trouble-free installation. We recommend that each section be reviewed prior to installation.

Although the DRV-1 and supporting documentation were designed to simplify the installation and on-going operation of your equipment, we recognize that the integration of motion control often requires answers to many complex issues. Please feel free to take advantage of our technical expertise in this area by calling one of our support personnel to discuss your application at 603-882-1447.

Thank You!  
Your AMS Team



## Product Overview

The DRV-1 is a high performance, microstepping driver designed to meet O.E.M. requirements for reliable, cost effective operation.

Features include:

- *Low cost - small size*
- *Heatsink Mounted*
- *31.25 KHz step clock*
- *Six resolution settings from full step to 1/32 step allowing for up to 6,400 steps/rev.*
- *1 amp output current (Peak)*
- *Over current protected*
- *Mating connectors included*

## Design Tips

EMI (electromagnetic interference or electrical noise) can be a major source of problems when integrating power drivers with microprocessor based devices. EMI is typically generated through ground loops and AC power line disturbances. External devices such as, relays, coils, solenoids, arc welders, motors, drivers, and other computer-based equipment are also sources of EMI.

The following design tips will help to prevent EMI from interfering with the system operation:

- Shield the driver and wiring by mounting it in its own metal enclosure as far away from noise sources as possible.
- Ground motor shields only at the driver end.

- Make sure that all power wiring (motor, AC, etc.) is away from the signal wiring (I/O, communications lines, etc.).
- Mechanical grounds should all be tied to Earth at a single point. Chassis and motor grounds should be tied to the frame and the frame to Earth.
- Ground all signal wiring to one point.
- Use solid-state relays or opto isolators whenever possible to isolate remote signals. Suppress all mechanical relays with capacitors or MOV's.
- Use shielded, twisted pair cables for the motor, I/O and communications wiring.

## Installation

The following installation procedure outlines the minimum steps required to make the DRV-1 operational:

1. Connect a 12Vdc to 34Vdc power supply to the 12-pin connector (J2) on the front of the DRV-1. Make sure pin 12 is connected to Vdc and pin 11 is ground. The power supply must be capable of providing 1 amperes. A typical power supply circuit is shown in the “Connecting Power Supplies” section of this manual.
2. With the power “Off” connect a motor to the 12-pin motor connector (J2) on the front of the DRV-1, using pins 6, 7, 8, and 9. Typical motor connection diagrams are shown in the “Stepping Motors” section of this manual. Be sure to insulate all motor leads and unused leads (6 lead motor) to prevent shorts to ground or to each other.
3. Set the appropriate current value using the potentiometer (Pot 1) on the front of the DRV-1. Turning the potentiometer clockwise increases the current and counterclockwise decreases the current. Be sure the current (output current) is set at a value that is consistent with the current rating of the motor.
4. Wire in your step, direction, and driver enable to either the front connector (J2) or the IDC-12 connector (JP-1). Wire the other end to the appropriate control module. Refer to the “Control Input” section of this manual for step and direction input connections and resolution settings.
5. Adjust current and resolution settings as required.
6. Apply power to the DRV-1.

### ***“Do’s, Don’ts and Important Notes”***

***Do not connect or disconnect the motor when power is “ON.”***

***The module case is tied to the logic common and power pins internally. Do not tie your power supply to ground at another location.***

***The power supply voltage, including ripple and line voltage fluctuations must not exceed 34Vdc or be less than 12Vdc.***

***Make sure the motor to be used is compatible with the drive.***

## DRV-1 Assembly Drawing

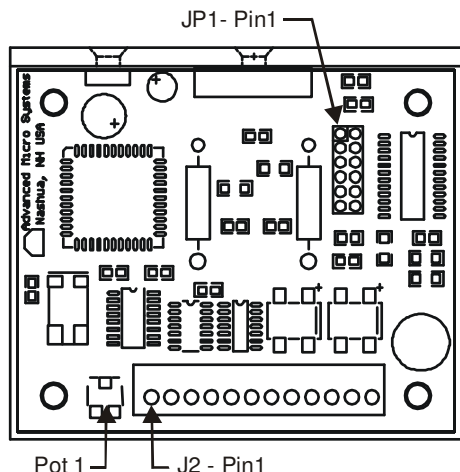

**Connector Description**

J2: Control Input/Motor/Power Connector

JP1: Control Input IDC connector

## Control / Motor/ Power Input (J2)

The essential input signals include a step pulse and direction control. Other inputs include three resolution select lines to permit remote select of microstep size (full step through 1/32).

Pin #	Description
1	VCC: +5Vdc output provided for user convenience permitting small loads up to 100 mA.
2	Step (In): Step clock input. Each pulse causes the motor to “step” one microstep.
3	Direction (In): Set the shaft direction for STEP input.
4	No Connection
5	No Connection
6	Motor Phase 1A output
7	Motor Phase 1B output
8	Motor Phase 2A output
9	Motor Phase 2B output
10	Disable: Low input shuts off power drivers.
11	Ground: Connect to common (GND) of controller.
12	12- 34VDC input of controller

## Microstep Resolution (JP1)

The number of microsteps per step is selected by the shunt located on pins 2, 4 and 6 of connector JP1. The jumpers at Pins 8 and 10 must remain installed for step and direction inputs.

Shunt M0 (Pin 1 to Pin 2)	Shunt M1 (Pin 3 to Pin 4)	Shunt M2 (Pin 5 to Pin 6)	Resolution	Steps/Rev.
In	In	In	Full	200
Out	In	In	1/2	400
In	Out	In	1/4	800
Out	Out	In	1/8	1,600
In	In	Out	1/16	3,200
Out	In	Out	1/32	6,400

## Stepping Motors

The DRV-1 is a bi-polar, chopper driver that works with both bi-polar and uni-polar motors, i.e. 8, 4 and 6 lead motors. It is also possible to half a 6 lead center tapped motor with the DRV-1, however the performance may be compromised.

The DRV-1 uses a constant chopping frequency and a varying duty cycle to sustain a given motor current. To avoid unstable chopping conditions and to provide a higher speed-performance ratio, a motor with a low winding inductance is preferred.

### Drive Current

The ideal current for a given motor is based on the specific characteristics of the motor and the requirements of the application. As a result, establishing the correct current is often determined empirically. Insufficient current will result in inadequate torque and under utilization of the motor. Excessive current can cause high-speed torque ripple, resulting in stalling or pole slippage, over heating of the motor and general inefficiency of the system. Current setting procedures are described in the next section; "Setting The Output Current (POT1)."

### Connecting a Stepping Motor (J2 pins 6-9)

Pin #	Description	Function
6, 7	1A, 1B	Phase 1 of the Stepping Motor is connected between Pin 6 and 7.
8, 9	2A, 2B	Phase 2 of the Stepping Motor is connected between Pin 8 and 9.

### Typical 4, 6 and 8 lead motor configurations

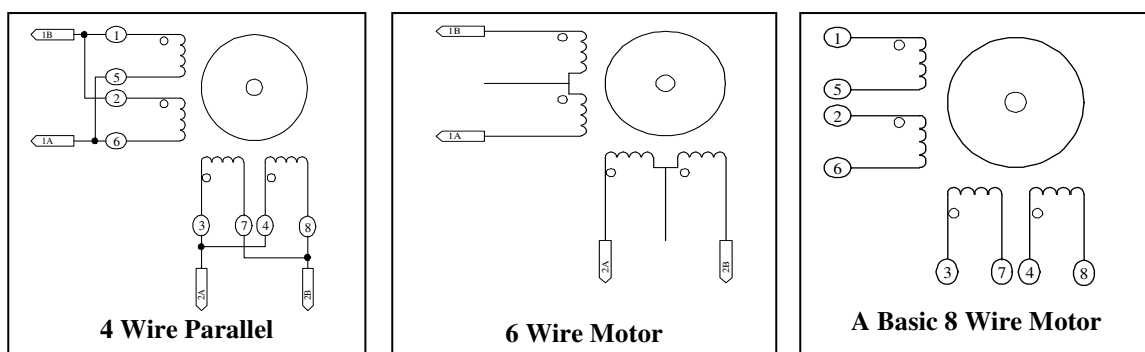

*“Do’s, Don’ts and Important Notes”*

*Do not connect or disconnect motor wires while power is supplied*

*When using a 6 lead motor be sure to insulate/isolate unused wires.*

*The physical direction of the motor with respect to the direction input will depend on the connection of the motor windings. To reverse the direction of the motor with respect to the direction input, switch the wires on phase 1 or phase 2 of the outputs.*

## Setting the Output Current (Pot 1)

A Potentiometer is used to set the DRV-1’s maximum current. Turning the potentiometer clockwise increases the current and counterclockwise decreases the current. Be sure the current (output current) is set at a value that is consistent with the current rating of the motor.

The actual motor current will vary based on a number of factors including motor characteristics, cable length and shielding. The Rule of Thumb is to set the output current just above the setting where reliable motion is achieved without excessive motor heating. **Refer to the Addendum; “About Step Motor Current” for more information.**

*“Do’s, Don’ts and Important Notes”*

*Make sure that some non-zero value of current is set.*

*Using low power values may cause a slight change in the motor resting position.*

## Connecting Power Supplies (J2)

The DRV-1 can be operated from a single unregulated DC power supply. The power supply is connected via pins 11 and 12 of the J2 Connector. The 5-volt logic supply is derived from an internal 5-volt regulator.

Pin	Function
11	GND
12	High Voltage

***Recommended Power Supply Circuit***

AMS recommends using an unregulated DC (or linear regulated) power supply. Switching power supplies are not recommended because of their inability to handle surge currents.

The single rectifier/filter can be used for single axis configurations, or multiple axes, provided component values are scaled accordingly. Alternatively, individual axes can be supported by their own rectifier/filter.

If multiple drivers are used with one power supply, each drive should have separate power and ground wires that connect directly to the output capacitor of the power supply.

*“Do’s, Don’ts and Important Notes”*

*Individual axes should be independently fused for fault isolation.*

*The power supply voltage, including ripple and line voltage fluctuations must not exceed the peak rating of 34Vdc or be less than 12Vdc.*

*Do not connect or disconnect motor wires while power is applied.*

*Wire size used to connect the power source to the driver should be at least 18 gauge. Heavier wire should be used for longer distances between the power supply and the driver.*

*The power supply output current needed is dependent on the supply voltage, motor selection and load.*

## Fault Protection

The DRV-1 is internally protected against over current conditions. If a peak output current exceeds the rated current, a latch is set and the phase associated with the over current condition is shut off. The next step pulse will sample the over current condition and, if it no longer exists, will reset the latch. Otherwise the latch will remain set until the next step pulse.

## Electrical Specifications

Parameter	Min	Typ	Max	Unit
Supply Voltage	12		34	Vdc
Supply Current			1	Amp
Output Current/Phase (PEAK)			1.2	Amp
Motor Chop Frequency		31.25		Khz

Recommended Fuse: 1 Amp MDL

### Input Signals:

Signals	Min	Typ	Max	Units
VCC Supply (internal)	4.7	5.0	5.5	Vdc
High Input Voltage	2.7	3.15	5.5	Vdc
High Input Current			40	Ua
Low Input Voltage	-0.7		0.9	Vdc
Low Input Current			.6	Ma

### Minimum Signal Timing

When the Step Clock Input goes low, the Direction and Microstep Select Inputs are latched. At this point, any changes to the inputs are disregarded until the next rising edge of the Step Clock Input. A step sequence is triggered with the negative going edge of the Step Clock Input. The minimum pulse width for the Step Clock Input is 1uS.

## Thermal/Mechanical Specifications

Operating Temperature.....0 to +50° C  
 Storage Temperature..... -40 to +125° C  
 Size.....3.1" x 2.7" x 1.0"  
 Weight.....3.0 Oz.

# Mounting Dimensions

