

**CCB-26 / DCMB  
HARDWARE MANUAL**



**Table of Contents**

Overview .....	1
Design Notes.....	2
Required Hardware .....	2
Output Drivers .....	3
Current Adjust .....	4
Serial Interface .....	4
Baud Rate Selection .....	5
Party Line Mode .....	5
Non-volatile Memory .....	5
Reset.....	6
Power Supplies .....	6
Input Ports.....	6
Phase Outputs .....	8
Phase Sequence.....	9
Electrical Specifications.....	9
Signal Pin Descriptions .....	10
Two Axis Mother Board (Model DCMB) .....	12
Two Axis Mother Board (Model DCMB) .....	13
DCMB Connectors .....	14
Naming Axis Procedure.....	15
CCB-26 Schematic.....	16
DCMB Schematic.....	17



## Overview

This document covers the hardware implementation of the CCB-26 and optional DCMB, an accessory dual-slot interface card. The heart of the credit card sized CCB-26 is a powerful controller chip called the SMC-26, a result of 20 years evolution of high performance motion control technology. The SMC-26 is a complete microcomputer with integral UART and program. It can produce step rates up to 19,000 steps per second. The extensive software communication protocol is covered in the SMC-26 Software Manual.

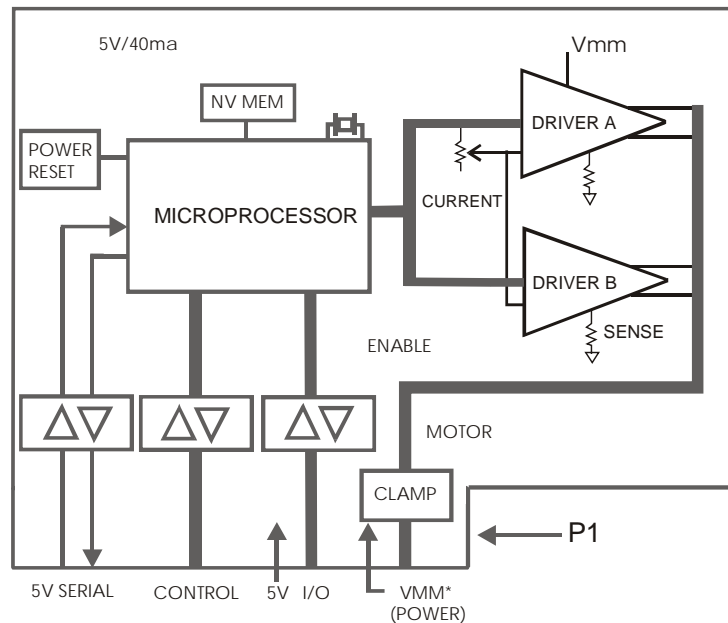

**Block Diagram: CCB-26 Driver and Intelligent Controller Board**

The CCB-26 has all the primary resources necessary to operate small to medium size step motors, including:

1. An embedded micro controller to:
  - Sequence micro step phases
  - Receive and execute serial commands
  - Execute commands stored in on-board NV memory
  - Monitor limit and home sensors
  - Operate input and output ports
  - Receive external step and direction signals
2. A quartz crystal to assure stable speeds and baud rates. Operation at 470k baud is also possible (see Baud Rate Selection).
3. Integral microstep drivers with a maximum rating of 1.0 amp per phase (with appropriate cooling). These bipolar drivers are capable of step resolutions to 1/8 step for extremely smooth operation.
4. Non-volatile memory, with a 10-year data retention, for storing command sequences. With this feature, once the instructions are loaded the computer or terminal is not necessary to execute the stored programs.

Programs can be started by:

1. A serial "G" (Go) command
2. A momentary pulse on the Go pin
3. A power up or reset sequence

The running program may be stopped by:

1. A serial ESC character
2. A momentary pulse on the Soft Stop pin
3. The normal end of instructions

## **Design Notes**

In its simplest form, the CCB-26 can operate with just a power supply, motor, and go pulse input. In most applications however, additional electronics are required.

### Logic I/O

While every effort has been made to protect the logic I/O from nominal abuse, caution must be exercised to **NEVER**:

1. Short circuit the motor outputs to each other or ground.
2. Apply more than 5.5 volts to any input or outputs.
3. Use long unshielded connections for any signal without buffering.
4. Locate the sensitive electronics near sources of electrical noise.
5. Place signal wires near sources of electrical noise such as motor leads.

### Minimum Design

For the minimum design a Go switch input, or step pulse and direction signal, is required. Here, a program sequence and parameter setup would have been previously loaded via the serial port.

### Basic Design

The basic design includes external RS-232 receivers and drivers that are commonly available. Some require  $\pm 12$  volts, but most are 5-volt devices. Multiple axes can be connected in parallel using a Party Line protocol.

Any input or output signals that run over several feet (shorter distances depending on prevailing electrical noise) should be appropriately protected from noise spikes that can cause erratic operation or a CPU crash. Methods include buffers, differential drives or optical isolation, depending on environmental hostility and conditions.

## **Required Hardware**

For prototyping and small volume production, AMS offers a motherboard that provides all the basic resources for a two axes system. See Section 2, "DCMB." The DCMB includes:

- Two CCB-26 card sockets
- Two 25 pin "D" connectors for I/O (these signals are not buffered)
- Two motor connectors
- RS-232 drivers and receivers
- A 5-volt regulator (allows single power supply operation)

For high volume production, without using the DCMB, a 40-pin edge connector (2 rows x 20 on 0.1 contact spacing), a 5-volt regulated power supply (rated at .15 amps) and additional circuitry are required.

Additional Required Hardware Using The DCMB

1. A motor power supply (Vmm), unregulated with surge capacity. For best performance, Vmm should be as high as possible without ever exceeding the rated voltage. See Electrical Specifications.
2. A step motor. For best performance the motor should be a 4 wire bipolar design. A high current rating indicates low winding inductance, hence higher speed capability. For the CCB-26 the maximum rated current per phase is constrained to about 1 Amp.
3. A serial interface adapter and cable assembly from AMS.

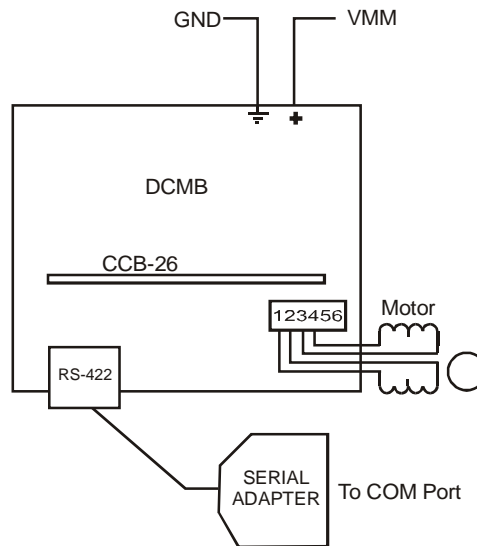
**Basic connection for a single axis system****WARNINGS**

***NEVER apply voltages in excess of 5.5 volts on any pin except the Vmm supply, as damage not covered by the warranty will occur. The output drivers are NOT short circuit protected. Excessive output currents WILL destroy the power drivers.***

**Output Drivers**

The CCB-26 implements two bipolar chopper drive I.C.'s. These devices are rated for a maximum of 1.0 amp at 50 volts. When the current is set above 0.75 amps at room temperature, the drivers will overheat if they are left enabled. Thermal shutdown will occur when the junction temperature exceeds +165 degrees C. Air cooling from a small fan **MUST** be used to prevent overheating under these circumstances. Use low duty cycles and auto power down to eliminate or minimize the additional cooling requirements. AMS is continuously developing better cooling techniques please contact us for the latest design news.

***Note: The CCB-26 DOES NOT have short circuit protection.***

### Current Adjust

A small trim pot (VR1) is used to adjust the current setting between zero and approximately 1.0 amp (full scale), as follows:

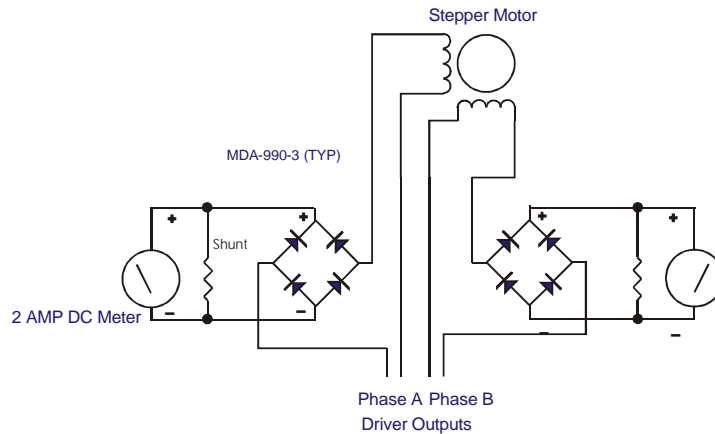

#### Suggested current measurement circuit

An analog meter movement provides a better, more “user friendly” average current reading than a digital meter. DVM’s can give false readings with chopped current waveforms.

#### Procedure

1. Insert an ammeter in series with one motor winding.
2. Adjust the pot (VR1) to ¼ turn from full CCW.
3. Apply power (both supplies should be turned on simultaneously).
4. Sign on with the computer.
5. Send the “E 1” command (enable current).
6. Step the motor as required to obtain the maximum reading.
7. Adjust the motor current (VR1) to the desired value.

A less scientific method would be to run the system at the highest expected speeds, adjust the current for reliable operation, then increase the pot setting by 20%. In all circumstances the motor temperature and driver temperature should be monitored. **Use Caution!** These temperatures can be so hot that you cannot maintain contact for more than several seconds.

### Serial Interface

The serial interface is used for either a full time communication to a host computer or a temporary means to test and load parameters or programs for future execution. The serial communication input is 5-volt logic.

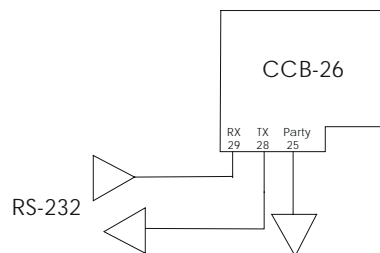

#### Single axis (dumb terminal) connection for name assignment

Several semiconductor manufactures supply RS-232, RS-422 or RS-485 line receivers. The older RS-232 devices require  $\pm 12$  volt power while more recent buffers such as the MAX-232 from Maxim or Linear Technology contain integral voltage generators. Once converted to 5-volt levels, multiple axes may be connected in parallel and operated in Party Line mode.

The output serial line is open drain with a 10k pull-up. These outputs are connected in parallel, and then buffered with the appropriate line driver for connection to the host.

### Baud Rate Selection

The normal baud rate is set at 9600. For operation at 470k baud, jumper W1 must be installed and the serial interface must use AMS' part number SIN-11, serial communication adapter.

### Party Line Mode

"Party Line" communication protocol is required when a host computer application, other than "dumb" terminal mode is used. This protocol greatly reduces communication time and supports multiple axis of motion from a single serial port.

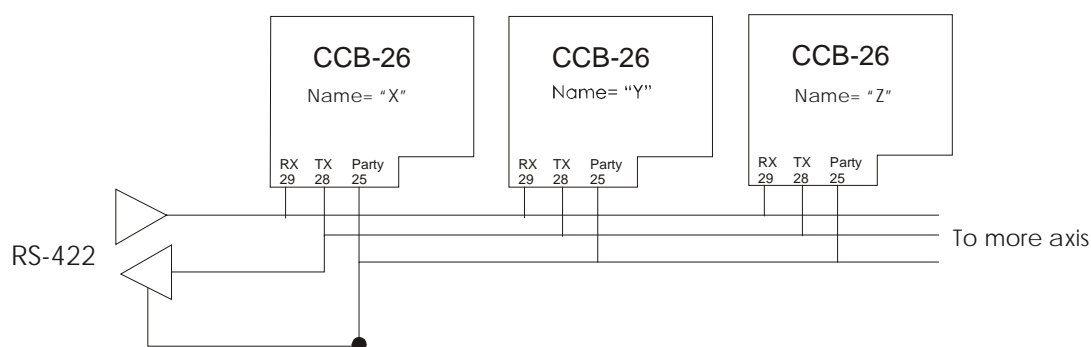

#### Party Line operation with pre-assigned names: X, Y, and Z

Two steps are necessary to achieve Party Line operation:

1. NAME ASSIGNMENT: Each axis on the serial "bus" must have a unique, single character name placed in its non-volatile (NV) memory. This is accomplished by placing an individual axis in the single (dumb terminal) mode, assigning a name and saving it in non-volatile memory.
2. START-UP: Once the names have been set and stored in memory the Party Line mode can be selected using the appropriate serial adapter.

See "Naming Axis Procedure" in DCMB section for more information.

### Non-volatile Memory

2048 bytes of non-volatile memory is available to store user programs. Many programs may coexist, limited only by the available memory space. The custom parameters, necessary to match controller capability to motor and system are determined and stored as your defaults. These include initial velocity, ramping slope, step mode, etc. Once the desired settings are determined the "S" command stores them in NV memory and will be used as your defaults. These parameters may also be temporarily modified during program execution, or by the host terminal.

## Reset

A special control circuit performs the power up reset function. A reset is then forced if the 5-volt logic power falls below approximately 4.3Vdc, protecting against unwanted operations.

Upon hardware reset all parameters (set by commands B,D,E,H,I,K,T,V) most recently saved are downloaded into the working registers of the controller. Both Jog and Go inputs are then active.

During reset all outputs are off. That is, they are at a 5-volt level because of the integral pull-up resistors. The “boot up” process takes several hundred milliseconds.

The final function after reset is to execute any instructions found at location 1600 in the NV memory. At this point the serial port is functional and an “Esc” character will abort the executing program.

## Power Supplies

Two voltages are required. The logic supply (Pin 27) requires a regulated +5-volts. The motor supply (Pin 39) Vmm does not need regulation as long as it will never exceed 48 volts during worst case (high line) conditions. Vmm may range between 5 and 45 volts. Ground (pins 1, 26 and 40) is common to all power supplies. Higher voltages for Vmm will result in better high-speed operation.

The optional two-axis motherboard (DCMB) includes a 5-volt voltage regulator with heat sink. The regulator will withstand 45 volts for single, unregulated supply operation.

### WARNINGS

***NEVER apply voltages in excess of 5.5 volts on any pin except the Vmm supply, as damage not covered by the warranty will occur.***

***The output drivers are NOT short circuit protected and excessive output currents WILL destroy the power drivers***

## Input Ports

**Pins 9, 11, and 15; Three general-purpose 5-volt input ports** are available for applications such as reading switches or other signals. The CMOS input ports P1 through P3 are protected with a 3.3k series resistor and a 10k pull-up to 5-volts. The input provides some degree of protection against accidental contacts with higher voltage sources. Depending on your design and environment, external buffers, isolation or filters may be implemented to protect against noise. These inputs are usable with the following commands:

Command	Description
A 128	Read port
L	Loop on port
G 2048	Branch on port

It is important to realize that these ports are defined as inputs because of the direction of the buffers on the board. The SMC-26 microprocessor software allows the user ports P1 through P3 to function as inputs and P4 and P5 to function as outputs. The “A” command permits the output of a low on any combination of these six ports, thus creating an output. The A 128 command will read all six of these ports and report the binary value representing the states when sampled.

A built in resistor (below) between the buffer and SMC-26 microprocessor is designed to protect against possible input/output conflicts.

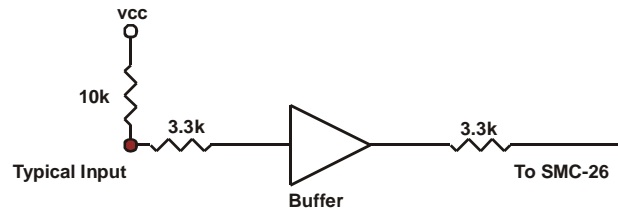

***A typical input circuit***

Applying voltages above or below the maximum ratings can cause damage. This circuit also applies to the home input, limit inputs, go and soft stop.

**Pins 7, 14, 18; Three general-purpose 5-volt output ports** for applications such as valve control or logic signals.

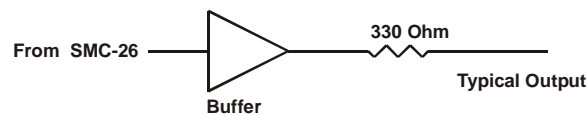

***A typical output circuit***

Applying voltages above or below the maximum can cause damage. Note that the protection resistor will reduce the output drive capability and must be considered when designing loads.

The following outputs DO NOT include current limit protection resistors: TXD, Direction, Moving, and the phase drivers.

**Pin 4; Home Input** is used by the Find Home command. The homing sequence has a special routine that helps remove the effects of mechanical backlash. If the home function is not used, then the home input may be read by the host as a general-purpose input. The “J” command will return the home input state.

**Pin 5; Moving Output** is an open drain status output that is low while moving. It may be or’ed with the corresponding outputs of other axis for use by the system. When a “host” computer is used, then the preferred method is reading of the motion status with the software command (^).

**Pins 6, 8; Limit Switch Inputs** are dedicated inputs that inhibit motion in one direction only. Prior to each motor step, the specific CW or CCW input is tested for an “on limit” state. When this happens, no more stepping is permitted in that direction, and the position counter does not change. The remainder of the index is terminated without ramping. A motion command in the opposite direction will be allowed, provided that the corresponding limit input allows it.

**Pins 10, 12, 13; Jog Control** provides a dual speed jog in both directions. Asserting a low level on pins 10 or 12 cause a “jog” or move at the speed specified in the first parameter (times 30) of the “B” command. When the level returns high, the stepping halts without any ramp. The direction CW or CCW is determined by which pin is asserted. A third pin (13) selects the second speed of jog specified by the 2<sup>nd</sup> parameter of the “B” command. If a jog input is held low and the “speed select” is asserted, ramping up that second speed occurs. Still holding the jog input and releasing the “speed” will cause ramping to the first speed. Releasing the jog input will cause termination without any ramping.

**Pins 16, 17; Soft Stop and Go Inputs** are used to control of pre-stored sequences. A low on the Go input will initiate the previously stored program, starting at NV location 00. This is comparable to the software “G 0” command. Program instructions can be a list of commands that are completed or can be constructed to run indefinitely. The Soft Stop input will cause deceleration (if the axis is moving) followed by termination.

The internal SMC-26 microprocessor “polls” these inputs, hence they must be asserted for a minimum time (recommended 10ms). While the program is running the serial command input is locked out, but will respond to an “ESC” or “^C” Abort command character.

**Pins 20, 23; External Step and Direction Inputs** are used as “slave” or remote signals. These two inputs permit use as an intelligent translator, accepting a user direction signal and step pulse. The following features are available:

1. The bi-directional position counter will track the position.
2. The limit switch inputs will function.
3. The step, direction, and phase outputs sequence.
4. If enabled, the Trip function will operate.
5. The hold current (power down) will function.

The input step rate is not buffered and caution must be exercised to avoid motor “stalls.”

**Pin 25; Party Line Select Input** is used to select the serial protocol between Single and Party Line communications mode. Single mode is a user-friendly communication that is intended for use during debug and familiarization with the operation. It is also necessary to assign and store the single character axis “name” that will be used in Party Line mode.

A low will place the pre-addressed axis into the Party Line mode. This mode should be used when communicating via application software, even if only one axis is used.

**Pins 28, 29; TXD Out and RXD In:** These 5-volt serial signals are used for communications. The RXD input is driven by an external RS-232 receiver. Most line receivers will drive many CCB-26 cards. The serial output is open-drain and should be connected (wire or’ed) in parallel before sending to a RS-232 driver. The optional dual axis motherboard (DCMB) includes an RS-232 interface and serial party-line expansion connections.

**Pins 19, 22, 23 and 24; are reserved.**

### Phase Outputs

The step sequence is determined by the controller.

Pin #	Phase Output	Drive Output
31, 32	Phase 3 (B 1)	Motor winding B
33, 34	Phase 2 (B 0)	Motor winding B
35, 36	Phase 1 (A 1)	Motor winding A
37, 38	Phase 0 (A 0)	Motor winding A

### Phase Sequence

The H command sets the phase switching sequence.

Sequence	H Command	Steps per Rev. (1.8 Deg. Motor)	Remark
1/8 Micro	H0	1600	Highest resolution (smoothest)
1/4 Micro	H1	800	Resonance reduced or higher resolution
1/2 Micro	H2	400	
Full-Wave	H3	200	1 phase on - low power
Half	H4	400	High torque - 1 phase/2 phase on
Full	H5	200	Highest torque - 2 phase on

### Physical Specifications (Size: 3.375 x 2.580 (in.), 20 pin edge connector mount)

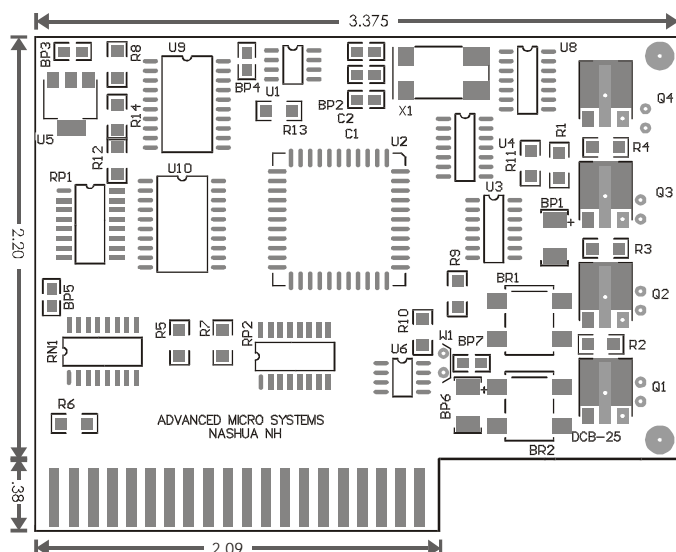

### Electrical Specifications

D.C. Characteristics, Logic

Description	Min	Typ	Max	Unit
Vcc	4.5	5.0	5.5	V
Icc: Supply current		45	110	Ma
Vil: Input low voltage	-.05		0.8	V
Iil: Input low current			-500.0	µa
Vih: Input high voltage	2.0		Vcc+0.555	V
Vol: Output low voltage	0		0.45	V
Voh: Output high voltage	4V		Vcc	V

Drive Outputs

Description	Min	Typ	Max	Unit
Bipolar chopper output range (adjustable)	0	0.75	1.0*	Amp
Motor power supply (Vmm)	5	28	42	Vdc

\*Over .75A per phase requires cooling airflow across heat sink(s). Thermal shutdown protection is built in.

## Signal Pin Descriptions

### Input Hardware

Unless otherwise stated, all inputs are 0-5 volt logic, with 10k pull-up resistors to Vcc. A 3.3k series resistor affords some protection from input surges to the CMOS series input buffers.

### Output Hardware

Unless otherwise stated, all outputs are 0-5 volt logic. Open drain outputs have 10k pull-up resistors to Vcc.

**WARNING! Exceeding the input or output ratings will damage the CCB-26 and may void the warranty.**

### P1 (40 Pin Edge Connector Signals)

Pin	Name	Function	Signal	Pin	Name	Function	Signal
1	NC			2	NC		
3	Port 4	Input	Logic	4	Home	Input	Logic
5	Moving	Output	OD	6	Limit A	Input	Logic
7	Port 5	Output	Logic	8	Limit B	Input	Logic
9	Port 3	Input	Logic	10	Jog 2 In	Input	Logic
11	Port 1	Input	Logic	12	Jog 1 In	Input	Logic
13	Jog Speed	Input	Logic	14	NC		
15	Port 2	Input	Logic	16	Soft Stop	Input	Logic
17	Go	Input	Logic	18	Port 4	Output	Logic
19	Reserved	In/Out	Logic	20	Ext. Dir.	Input	OD
21	Dir.	Output	OD	22	Reserved		
23	Ext Step	Input	Logic	24	Reserved		
25	Party Line	In/Out	Logic	26	Gnd	Power	Com
27	Vcc 5 volt	Power	5v	28	TXD	Output	Logic
29	RXD	Input	Logic	30	NC		
31	Ph 3 Drive	Output	Vmm	32	Ph 3 Drive	Output	
33	Ph 2 Drive	Output		34	Ph 2 Drive	Output	
35	Ph 1 Drive	Output		36	Ph 1 Drive	Output	
37	Ph 0 Drive	Output		38	Ph 0 Drive	Output	
39	Vmm	Power		40	Gnd	Power	Com

***DCMB  
2 AXIS MOTHER BOARD***



**Two Axis Mother Board (Model DCMB)**

The DCMB is an accessory to the CCB-26. It contains the interface for one or two axis of motion control. The expansion connector provides the ability to add more axes in a microprocessor-based system.

- Two axis interface
- Expansion connector for multi-axis
- 1 amp, 5-volt regulator for additional load
- DB-25 connector for input/output signals
- DC or 8-40 VAC input for low cost power
- Separate motor and power supply inputs
- RJ45 connector for RS-422 input

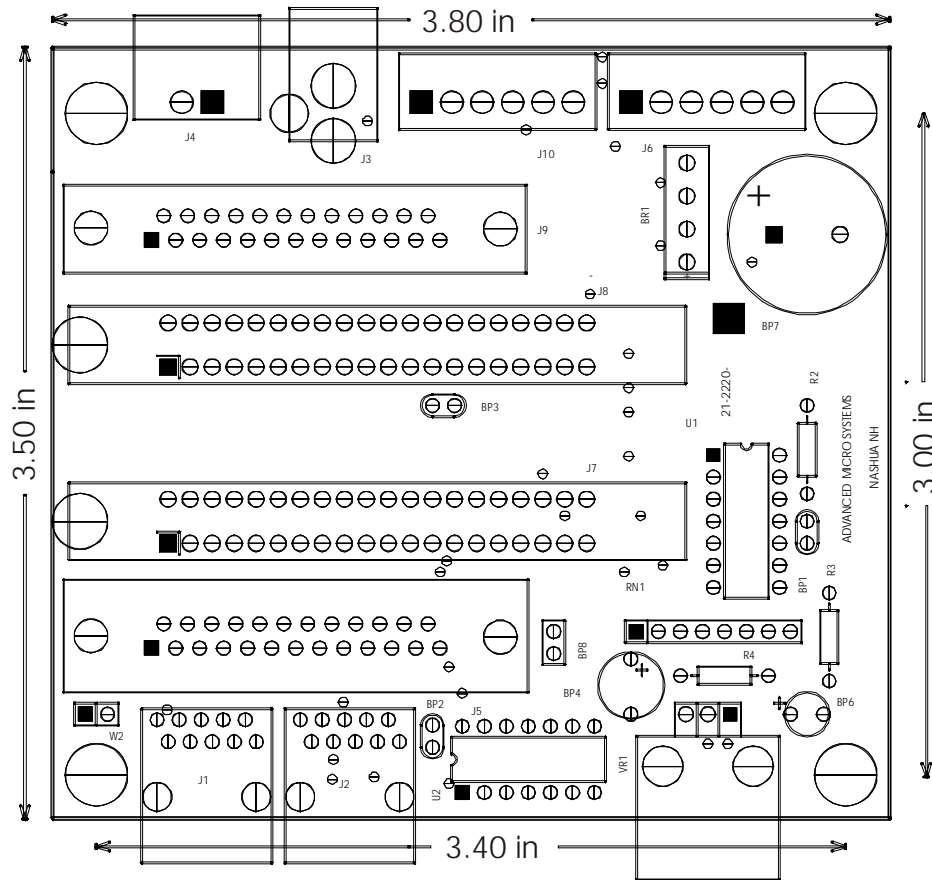

**Dual axis motherboard with 8-40 VAC input, 5-volt regulator, RS-422 interface and Party Line expansion**

An RS-422 input converts standard serial voltages to TTL levels to drive up to 32 axes. The open drain TXD outputs from each axis are wire-or'd, providing "Party Line" communication.

**DCMB Connectors**

J1- RS-422 Interface

The J1 modular RJ45 connector serves as an RS-422 interface. The receiver and transmitter signals meet EIA specifications. An available serial adapter module (SIN-11) allows convenient plug-in compatibility to the host computer.

Pin	Signal	Type	Pin	Signal	Type
1	Moving	Output	5	TXD+	Output
2	Gnd	Logic	6	RXD+	Input
3	RXD-	Input	7	+5-volt	Logic
4	TXD-	Output	8	Party Enable	Input

J1, J2  
Pin 1

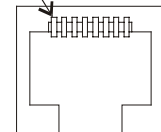

J2- Party Line Extension

J2 allows convenient "Party Line" connection to the next axis.

Pin	Signal	Type	Pin	Signal	Type
1	Moving	Output	5	TXD+	Output
2	Gnd	Logic	6	RXD+	Input
3	RXD-	Input	7	N/C	
4	TXD-	Output	8	Party Enable	Input

J3- AC Input

A standard 5.5 mm jack provides input options for low cost AC power transformers. A 9V (1 amp or higher) AC transformer can be used for typical 12Vdc motors. A DC supply may also be applied but approximately 1.5 volts will be lost in the 1 amp rectifier. The unregulated voltage (approximately 12Vdc) is available on J4.

J4- Vmm Input Power

This input can be used as a power input in place of J3.

Pin	Signal
1	Vmm (8-40 Vdc)
2	Gnd (0 volts)

J6, J10 Motor Connector

A six-pin power connector is designed to accept each wire from a 4, 6, or 8-conductor motor.

Pin	Signal
1	Ph 3
2	Ph2
3	Ph1
4	Ph0
5	Vmm (center tap Ph2 and Ph3)
6	Vmm (center tap Ph0 and Ph1)

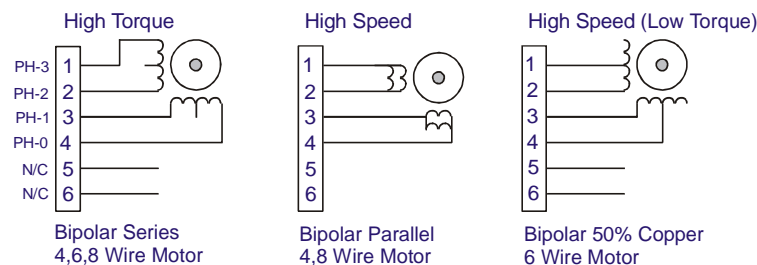

I/O 1, and I/O 2 Input/Output Signals

Two convenient DB25 connectors provide access to all input and output signals. All signals are 5-volt logic levels, rated at 1mA source or sink. Inputs have a 10k pull-up resistor.

Pin	Name	Function	Signal	Pin	Name	Function	Signal
1	Port 2	Input	5-volt	14	Vcc	Power	5-volt
2	Port 4	Input	5-volt	15	Home	Input	5-volt
3	Moving	Out	OD	16	Limit A	Input	5-volt
4	Port 5	Out	5-volt	17	Limit B	Input	5-volt
5	Port 3	Input	5-volt	18	Jog 1	Input	5-volt
6	Port 1	Input	5-volt	19	Jog 2	Input	5-volt
7	Jog Speed	Input	5-volt	20	Port 6	Output	5-volt
8	Gnd	Power	Com	21	Soft Stop	Input	5-volt
9	Go	Input	5-volt	22	Port 4	Output	5-volt
10	Ext Dir.	Input	5-volt	23	Dir.	Output	OD
11	Step	Output	5-volt	24	Gnd	Power	Com
12	Ext Step	Input	5-volt	25	Gnd	Power	Com
13	Chop	Input	5-volt				

**Naming Axis Procedure**

To communicate with the CCB-25 and/or CCB-26 one of the following serial adapters are necessary:

**Single Axis**

1. SIN-7 (25 pin) or SIN-9 (9 pin), RS-232 to RS-232 serial adapter and cable used for communication with one axis in single axis mode.

**Multi-Axis**

2. SIN-8, RS-232 to RS-422 serial adapter and cable. It permits addressing of up to 32 axes from a single serial port.
3. SIN-10 and SIN-11, Intelligent serial line converters. These adapters are used with operating systems that are difficult to interface with, such as Windows 2000 and Windows NT.

The following procedure is used for multi-axis "Party Line" applications to assign an axis "Name" to the CCB-26/CCB-26 using the DCMB motherboard:

1. Turn the power "OFF."
2. Connect the serial adapter from your serial port to J1 on the DCMB.
  - SIN-8: Move the red selector switch to the "S" (single line) position.
  - SIN-10: Move the Party Line switch (S8) to the "off" position.
  - SIN-11: Ready as is.
3. Remove all CCB-25/CCB-26's from the DCMB.
4. Install the first CCB-25/CCB-26 in the DCMB (either slot).
5. Turn the power "ON."
6. Enter the "Name" character: (A-Z, a-z) followed by a space bar. The CCB-25/CCB-26 will sign on.
7. Verify by entering the "X" (Examine) command <CR>. The last "n" value should be the Name assignment.
8. Enter the "S" (Save) command <CR>. The Name is now stored in the NV memory.
9. Turn the power "OFF."
10. Remove the first CCB-25/CCB-26.
11. Install the second CCB-25/CCB-26.
12. Repeat steps 5 through 11 for each CCB-25/CCB-26.
13. Prior to programming, if you are using a:
  - SIN-8: Move the red selector switch to the "P" (Party Line) position.
  - SIN-10: Move the Party Line switch (S8) to the "on" position.
  - SIN-11: Enter the Amper (&) sign

CCB-26 Schematic

